

# MANUAL TIP DRESSER



ETD-18F

- Compact, Light Weight and Easy to Use
- No need to remove Electrode Tips from welding machine
- Cutter Blades to suit various shapes of Electrodes
- Fully Imported From Japan

## TIP DRESSER

Model No.	Electrode Tip Diameter mm	Free Speed r.p.m.	Overall Length mm	Net Weight kg	Air Consumption m <sup>3</sup> /min	Air Inlet PT
ETD-18F	10 to 18	1,300	290	1.6	0.2	1/4"

## CUTTER-CASE

Model No.	Tip Size (A) mm
ETD-0-10	10 dia
ETD-0-12	12 dia
ETD-0-13	13 dia
ETD-0-16	16 dia
ETD-0-18	18 dia

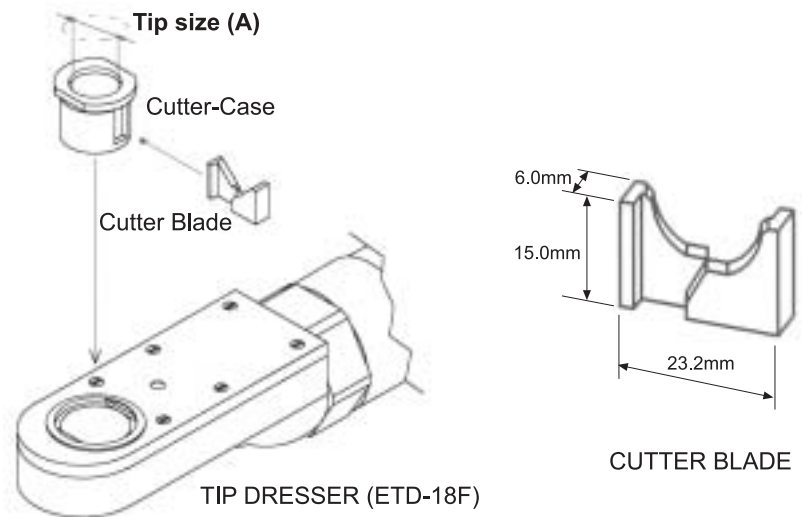

## CUTTER BLADE PROFILE

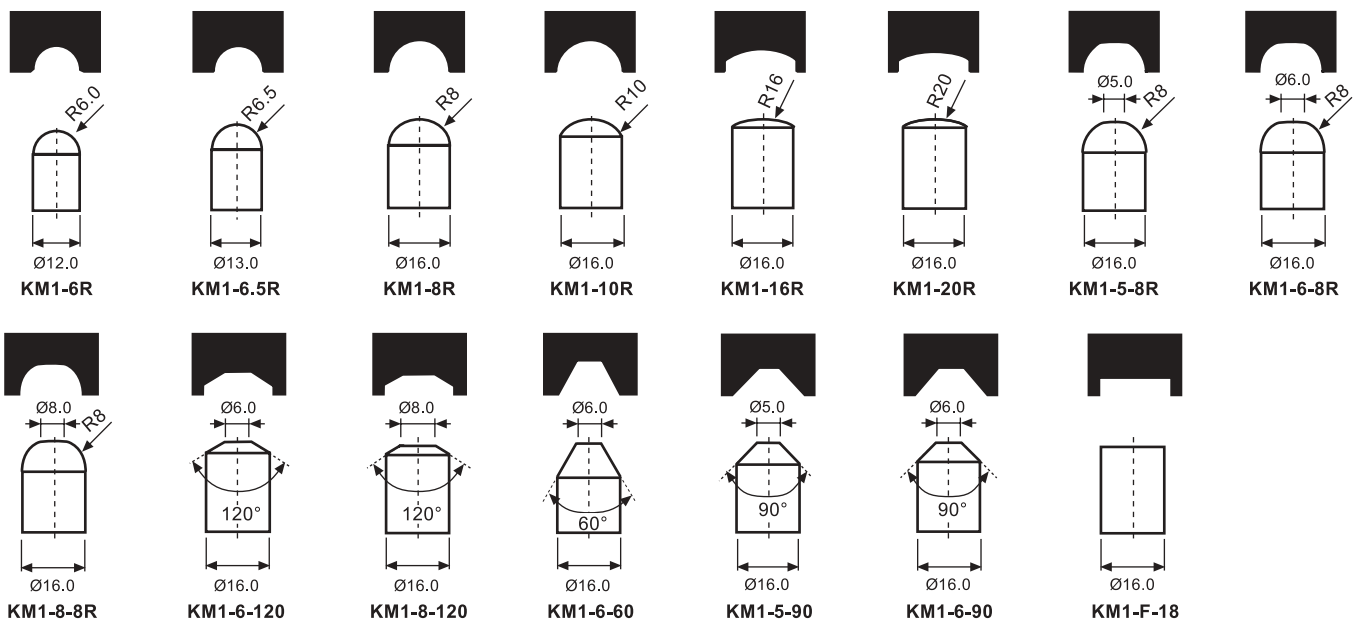

**INDUSTRIAL POWER ENGINEERING SDN. BHD.**

Company No. 58073-A

16 Jalan SS 4/17, 47301 Petaling Jaya, Selangor Darul Ehsan, Malaysia.

Tel: 603 - 78747109 (Hunting Line) Fax: 603 - 78765105 Email: [ipebfw@po.jaring.my](mailto:ipebfw@po.jaring.my)